

Attached Diagram.

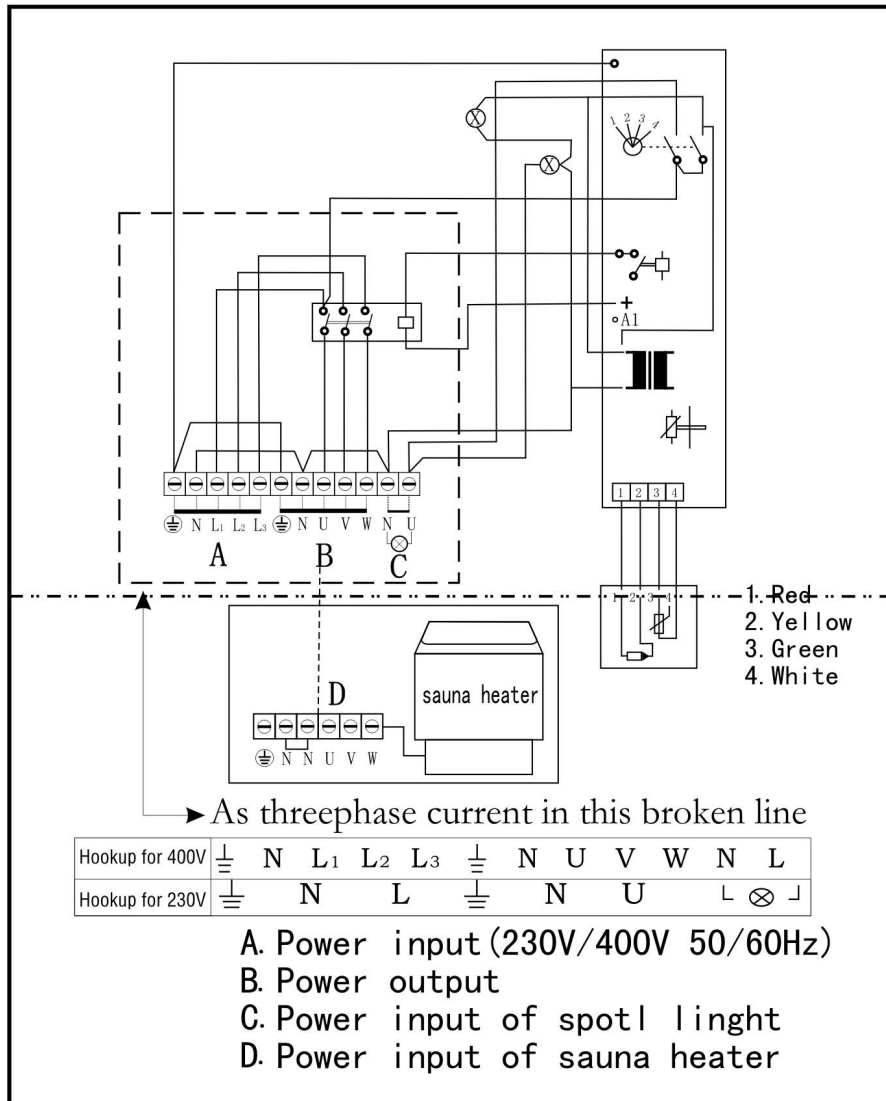

SAUNA HATER WITH EXTERNAL CONTROL PANEL

INSTALLATION MANUAL (DIGITAL DISPLAY)



Use ordinary drinking water only.

Other materials poured into the stone compartment may damage the heating elements, which is beyond our guarantee.

- ① Contactor model Lcl-D1810 used for sauna heater 3-9KW
- ② Contactor model Lcl-D2510 used for sauna heater 10.5-15KW

WARNING:

PLEASE READ THIS MANUAL CAREFULLY BEFORE USE

WARNING: PLEASE READ THIS MANUAL CAREFULLY BEFORE USE

The control panel is of splash proof model and can be installed in a dry place near sauna room. The temperature sensor unit must be installed to the wall in sauna room. For installation please follow the minimum safety distances of sauna heater indicated in installation diagram. Failure to follow these may cause a burn to the wooden wall. (See details in the following figures)

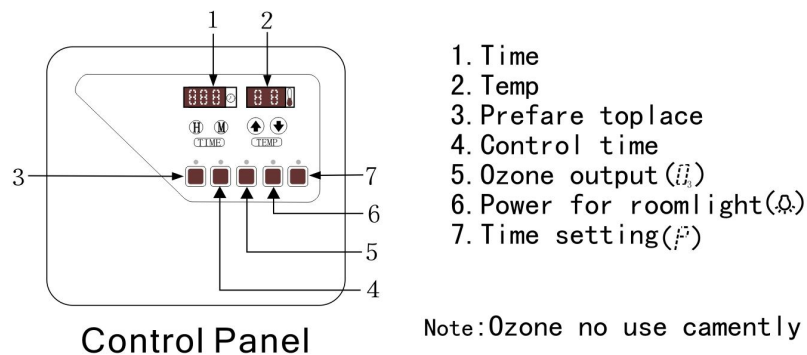

Control Panel

Operation manual of transfer switch and timer/thermostat

A. Adjusting present time : press H to adjust hours until the figure comes stable press M to adjust minutes.

B. Drepare to place : (Max 24 hours)

press to fix the time and then press button P until the lumination off.

C. Control time ; press button P and then press button to fix the time (Max 4 hours and uin. 10 minutes) until the lumination off.

Sauna Rocks

Load adequate sauna rocks (10-15kg) into the sauna heater after finishing the installation of sauna heater and controller.

ATTENTION: Sauna rocks must be of finest qualities because temperature inside sauna heater is extremely high. Rocks not be able to withstand heat and the great heat changes easily break or get crumbling and damage the heating elements, or are easily oxidized which in return counteract the heat circulation and damage the sauna heater while being heated or being thrown water to for vapors causes.

WARNING

1. Electrical shock hazard -----there are no owner serviceable parts in sauna heater. To avoid electrical shock hazard, all installations and relevant services shall be performed by qualified personnel.
2. Sauna shall be less than half an hour. Bathing too long may cause heart beating too fast, light heartache, feeling weak or dizzy. Should the bather stop bathing immediately as soon as the above symptoms occur.
3. Sauna bath may cause tension to the bather. Thus, one who is one of the followings should be directed by physician:
 - A. Being pregnant
 - B. Having heart disease
 - C. Having high blood pressure
 - D. Having circulation system disease
 - E. After drinking
 - F. After taking medicine.
 - G. Diabetes
 - H. Not feeling well.
4. Children must be under the company of adult in taking sauna bath.
5. Risk of scald: Must not touch the sauna heater or trim during heating, as it is hot. Stay at least 30 cm away from the hot heater.

GUARANTEE

1. Control panel is under one year guarantee.
2. Main body of sauna heater is under one year guarantee.
3. The following situations are not guaranteed:
 - 1) Installation or internal structure disassembling by unprofessional personnel
 - 2) supply voltage fluctuation range $> \pm 10\%$
 - 3) unqualified rocks on sauna heater's compartment
 - 4) installation without following the dimension instruction of manual