

Technical Specifications

Focus





Technical Configuration

1. Technical Data Sheets
2. Presentation and choice of rail
3. Drilling recommendations
4. Dimensions of the cover
5. Permitted obstacle(s)
6. Required water level
7. Mirror pool

1. Technical Data Sheet (V10) Semi-Automatic Model

Specifications

4-season safety cover that complies with the **AFNOR NF P 90-308 January 2023**

- 
Manipulation:
 - Portable control box equipped with 2 batteries: 12v 2,9Ah (XS and S) or 12v 5,5Ah (M and L)
 - Ratchet spanner only in case of an electrical failure
- Power supply:** Independent charger to plug into a 100 - 240V socket
- Membrane:** PVC pre-stressed membrane 670 g/m² (standard colors: RAL 7035 & 7037)
- Belt:** Polyurethane with stainless steel cables
- 
Mechanical:
 - All the metallic parts involved in the security are in anodized aluminium and 316 stainless steel
 - Lifts allowing obstacle clearance, use in low-clearance situations, and ensuring sealing
- Rails:** Anodised aluminium 36 x 10mm
- Casing:** Polyester powder-coated aluminium, matt finished (standard colors: RAL 7035 & 7037)
- 
Length: Min 2 meters → Max 28 meters
- Width:** Min 2 meters → Max 10.5 meters (depending on the length of the cover)¹
- 
Speed: Closing/opening time: 60 seconds for a length of 13 meters



Available membrane colours



Available casing colours



Available options

- All-terrain rail (RTT) 72,0 mm x 10,6 mm (refer to chapter 2A)
- "Champagne" color rail (only standard rail)
- Closing sensor (wired or RF)
- Side crushing³

Measures (in mm)

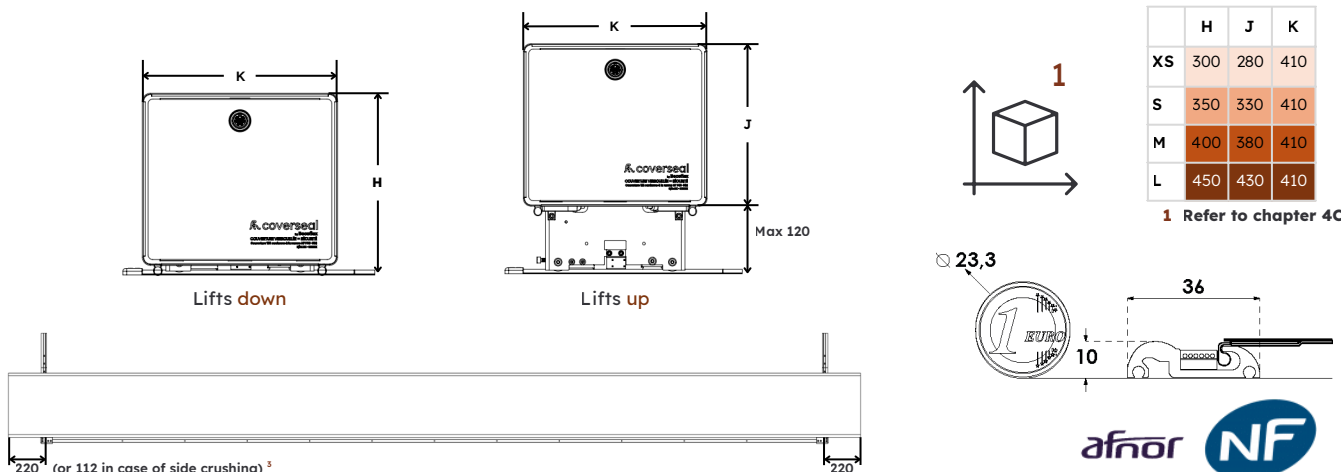

Specifications

4-season safety cover that complies with the **AFNOR NF P 90-308 janvier 2023**



- Manipulation:**
 - Bluetooth application via smartphone (Android/Apple)
 - Wired control with 3 buttons
 - Ratchet spanner only in case of an electrical failure
- Power supply:** Rechargeable by 1 solar panel 12V/30W (333 x 500mm) of 2 batteries 12V-5.5Ah (except indoor pool = on power supply)

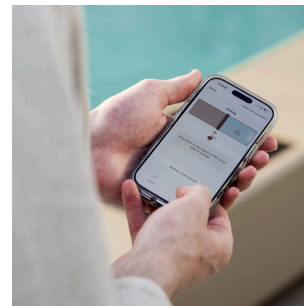

- Membrane:** PVC pre-stressed membrane 670 g/m² (standard colors: RAL 7035 & 7037)
- Belt:** Polyurethane with stainless steel cables
- Mechanical:**
 - All the metallic parts involved in the security are in anodized aluminium and 316 stainless steel
 - Lifts allowing obstacle clearance, use in low-clearance situations, and ensuring sealing



- Rails:** Anodised aluminium 36 x 10mm
- Casing:** Polyester powder-coated aluminium, matt finished (standard colors: RAL 7035 & 7037)
- Length:** Min 2 meters -> Max 28 meters
- Width:** Min 2 meters -> Max 10.5 meters (depending on the length of the cover)¹



- Speed:** Closing/opening time: 60 seconds for a length of 13 meters

Available membrane colors



Available casing colors



Available options

- All-terrain rail (RTT) 72,0 mm x 10,6 mm (refer to chapter 2A)
- "Champagne" color rail (only standard rail)
- 1 additional solar panel
- Side crushing³
- Closing sensor (wired or RF)
- Charging station for indoor pool

Mesures (en mm)

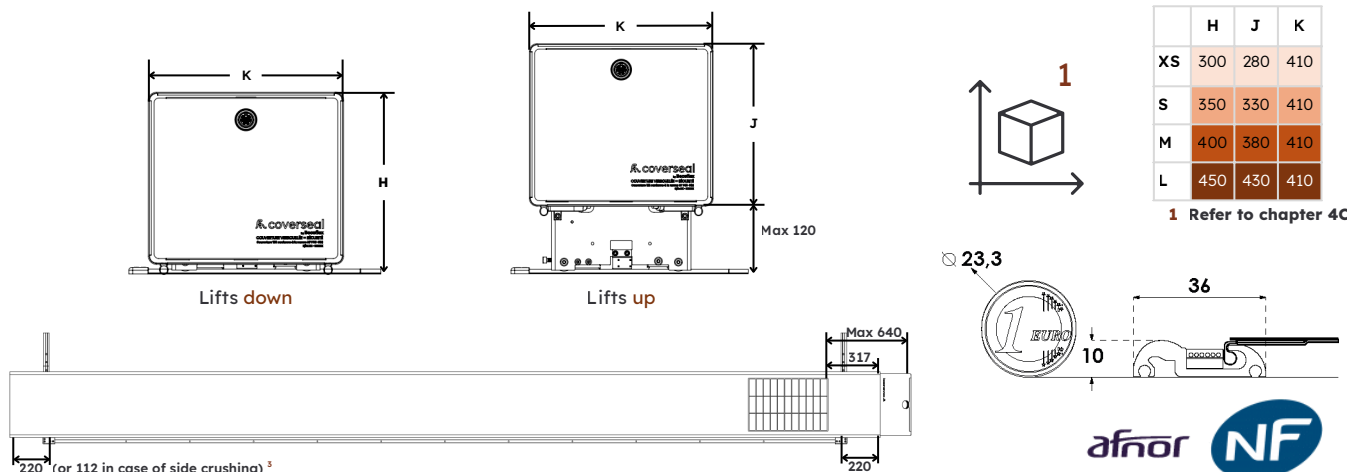

A. Authorised surfaces

1. Dense and regular surfaces

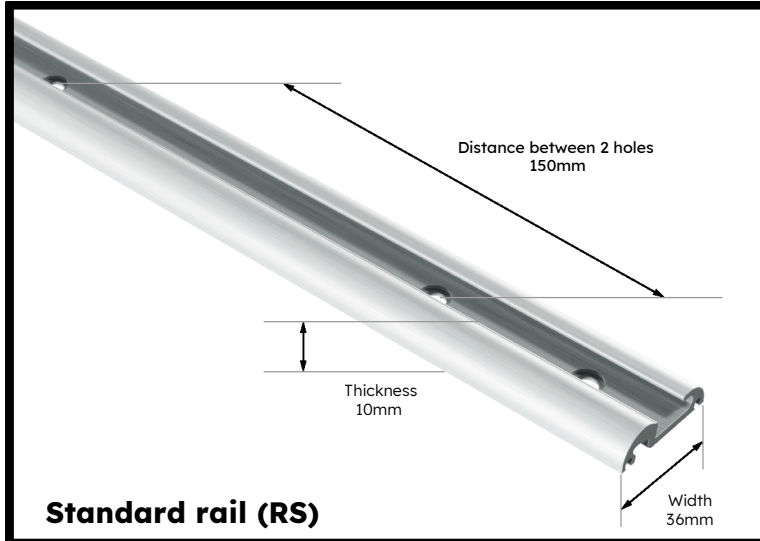

-  Smooth natural stone
-  Ceramic
-  Dense wood (p > 650kg/m³)
-  Smooth concrete slab

2. Low density and/or irregular surfaces

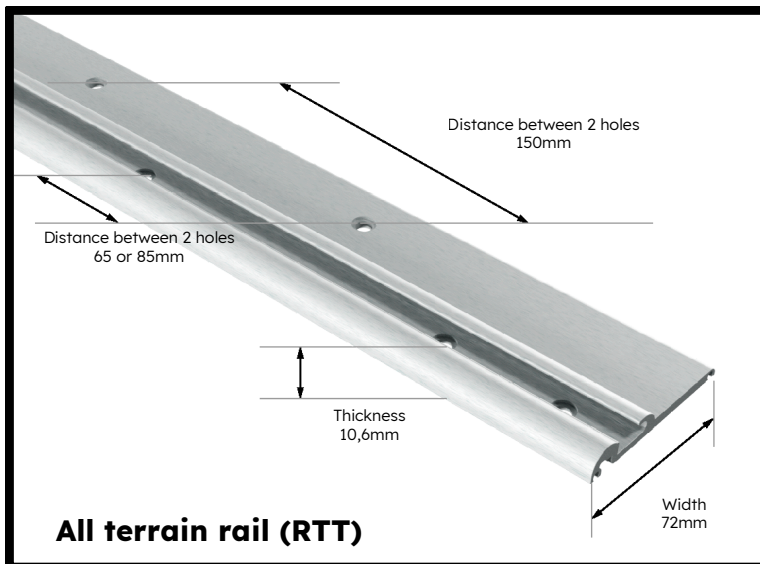

-  Paving stones
-  Soft wood (p < 650kg/m³)
-  Solid composite
-  Brick on edge
-  Klinkers

B. Forbidden surfaces

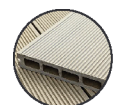

Hollow composite



Rubber mat



Support with slope towards pool



Support with slope > à 4% ou 2,3°



Others

Case	Installation	Rails	Screw length	Drill depth	# screw anchors
Smooth natural stone / Ceramic sandstone	On coping stones of thickness < 20mm	Standard	100	130	2
	On coping stones of thickness ≥ 20mm	Standard	150	200	2
	On the terrace	Standard	100	130	2
Smooth concrete slab	/	Standard	75	90	1
Bricks on edge/pavers/klinkers	/	RTT	150	200	2
Stone carpet	If thickness <10mm	Standard	100	130	2
	If thickness between 10 and 30mm	RTT	100	130	2
Dense wood (ρ>650 kg/ m3)	/	Standard	25/75	/	/
Soft wood (ρ<650 kg/ m3) or plain composite	On boards perpendicular to the rails	RTT	75	/	/
Fixing on metal	On stainless or galvanised steel profile min. 2mm OR Aluminum min. 3mm	Standard	Rivet Ø4,8mm x (Length min. 4mm + profile thickness)		

Please refer to the Definitive Technical Configuration document for an in-depth analysis of authorised anchoring surfaces and supports, including recommendations and obligations.



To calculate "O/P"

1. Flat coping / No coping

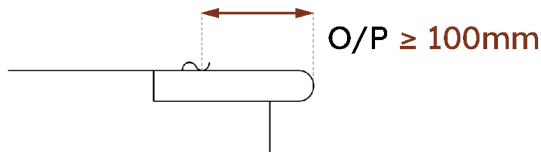

2. Curved coping

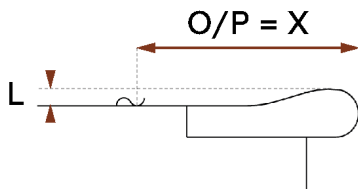

Minimum distance "X" mm depending on the height of the obstacle (see formula or table below).

Example:
If the width between coping stones (B) is 4000mm and if "L" is 40mm THEN « X » minimum = 240 mm (4x60mm)

$$(Q) = 4000\text{mm (B)} + 240\text{mm (O)} + 240\text{mm (P)} = 4480\text{mm}$$

3. Raised flat coping

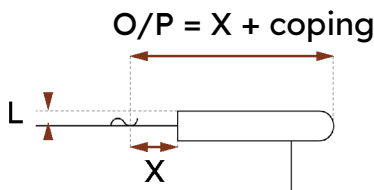

Minimum distance "X" mm depending on the height (see formula or table below) to which the width of the coping must be added.

Example:
If the width between copings (B) is 5000mm, if "L" is 20mm and the width of the coping is 300mm THEN
"X" minimum = 120mm (2x60mm) and $O/P = (120+300)$
 $(Q) = 5000\text{mm (B)} + 420\text{mm (O)} + 420\text{mm (P)} = 5840\text{mm}$

4. Raised curved coping

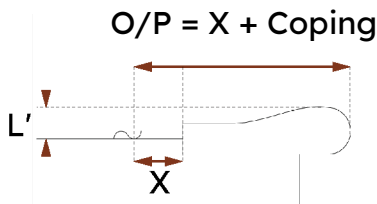

Minimum distance "X" mm depending on the total height "L" (see formula or table below) to which the width of the coping must be added.

Example: if the width between the copings (B) is 4000 mm, if "L" is 50 mm and if the width of the copings is 250 mm THEN
"X" minimum = 300 mm (5x60 mm) and $O/P = (300+250)$
 $(Q) = 4000 \text{ mm (B)} + 550 \text{ mm (O)} + 550 \text{ mm (P)} = 5100 \text{ mm}$

Formula:

Distance minimum "X" = 60mm par 10mm (curve/heightening)

Example: If curve/heightening = 30mm THEN "X" minimum = 180mm (3x60mm)

Table:

Minimal distance « X » in mm		Height curve/obstacle "L of L"						
		50	60	70	80	90	100	110
Inside width of the pool between copings in mm (B)	2 000	430	940	N/A	N/A	N/A	N/A	N/A
	3 000		450	630	850	1110	1390	N/A
	4 000			480	640	830	1050	1290
	5 000				520	670	840	1030
	6 000					560	700	860
	7 000							740

* N/A = Not admitted

A. Opening/closing overlap (R= M+A+N)

To calculate the minimum total length of the cover (R), take the inside length between coping stones (A) to which must be added the overlap in opening and closing (M+N).

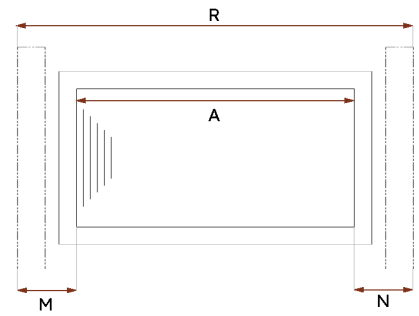

To calculate “M/N”

1. In opening (accessible pool)

To the length of the pool, must be added a minimum distance of 500mm from the end of the stone or behind a trap that must remain accessible (example: skimmer).

If it's impossible to free access to this trap, it's possible to do a "skimmer cut" in the membrane (maximum Ø 400mm)

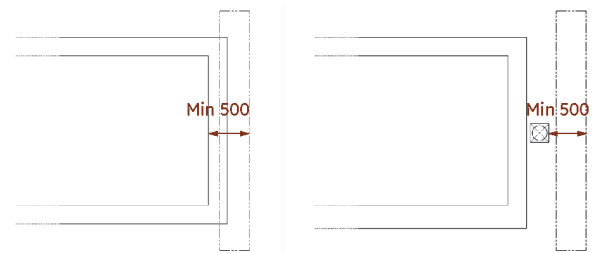

2. In closing (inaccessible pool)

To the length of the pool, must be added a minimum distance of 500mm from the end of the stone to provide an optimal sealing.

The surface must be perfectly flat in the open and closed position to allow the the covering to rest on the floor.

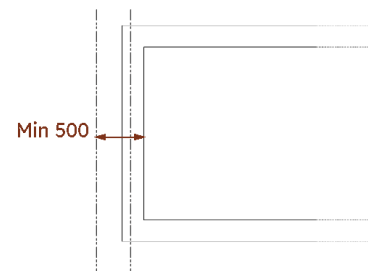

B. Rail spacing (Q= O+B+P)

To calculate the minimum total width of the cover, take the inside width between coping stones (B) to which must be added the necessary distance on each side (O+P) for a good anchoring respecting the following cases.

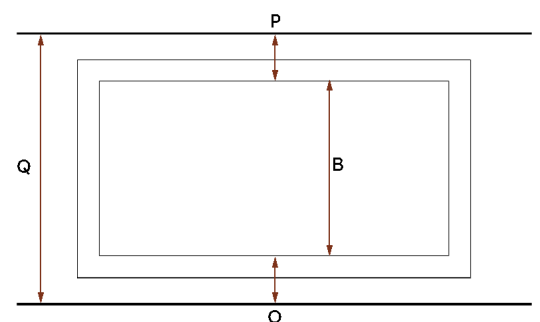

C. Maximal dimensions

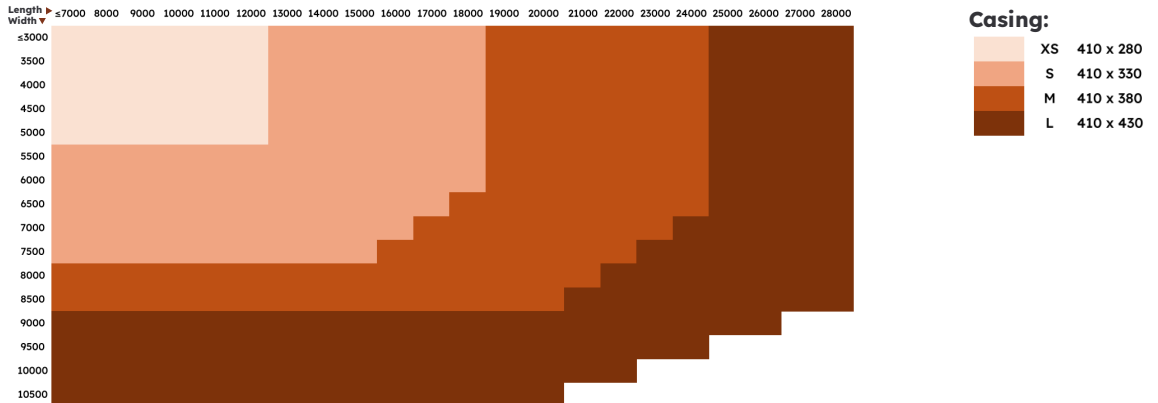

5. Authorised obstacle(s)

It is imperative to respect the table below to allow the mechanism to pass.

Max height of obstacle "Z" (in mm)	Models			
	Semi-Automatic, Automatic			
	XS	S	M	L
6000	50	70	100	120
7000	45	65	95	115
8000	40	60	90	110
9000	35	55	85	105
10000	30	50	80	100
11000	30	45	75	95
12000	30	40	70	90
13000		30	65	85
14000		30	60	80
15000		30	55	75
16000		30	50	70
17000		30	45	65
18000		30	40	60
19000			35	55
20000			30	50
21000			30	50
22000			30	45
23000			30	45
24000			30	40
25000				40
26000				35
27000				35
28000				30

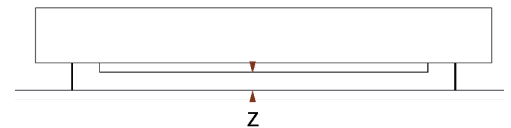

6. Required water level

The distance between the top of the coping and the pool water level must always be within the following ranges.

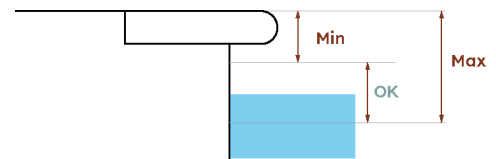

Width of the pool	< 4m	4 to 5m	5 to 6m	6 to 7m	7 to 8m	8 to 9m	9 to 10m	10 to 11m	11 to 12m
Minimum distance (Min) "Z"									
Flat curbs (up to 20 mm obstacles) and dense surfaces	4cm	5cm	6cm	7cm	8cm	10cm	12cm	14cm	16cm
Other case	8cm	10cm	12cm	14cm	16cm	18cm	20cm	22cm	24cm
Maximum distance (Max) "Z"									
For every case	15cm	17cm	19cm	21cm	23cm	25cm	27cm	29cm	31cm



Unlike a traditional pool, the water in a mirror pool does not follow a simple circuit: skimmers → pump → filter → pumps.

Instead it follows: overflow, trough → buffer tank → pump → filter → discharge
Hence the water line and the deck sections are at the same level.

Storm water release:

- The highest lip of the Coverseal rail should be at least 2mm lower than the pool water level once the pump is in operation.
- In the event of rain, it is essential to run the filtration system (pump) continuously to prevent water accumulating on the membrane and to allow it to escape, thereby maintaining the coverage to the AFNOR standard.

However, if the filtration has to be stopped and a quantity of rainwater has collected on the cover, the pump must be put back into operation to allow the water to be removed.

Cases:

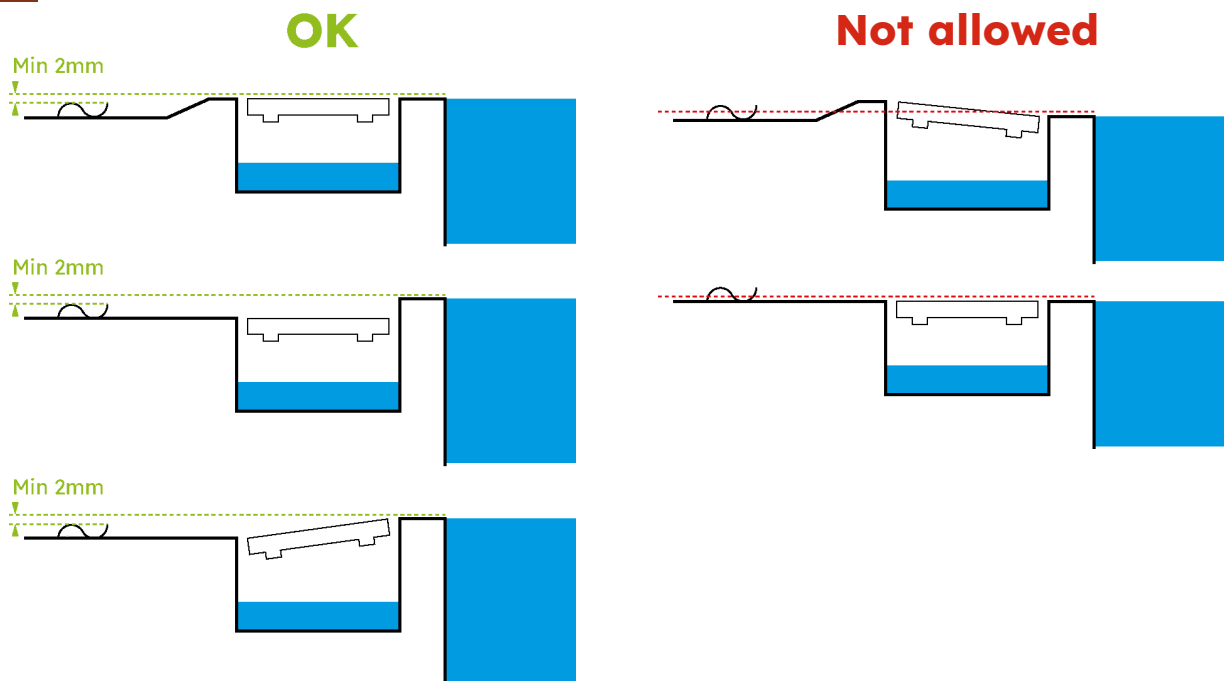

Pre-sale inspection at the customer's premises:

- The slope of the surround must always drain the water to the outside of the pool
- The water level must be higher than all the elements between it and the rails.

In production :

During the manufacturing of the membrane, no drainage holes are made except for the first 60 centimeters, in order to prevent water accumulation during rolling.